

PRINCIPAL SPECIFICATIONS

Model Number	RF/LO Center Frequency, f_0 , MHz	LO Bandwidth (LO Port) Min.	Conversion Loss, dB, (RF to I or Q)		Quadrature Bal., (I to Q) LO				Amplitude Balance, LO		
			Max.	Typ.	at f_0	LO over Rated Band	LO over Rated Band	at f_0 , dB, Max.	LO over Rated Band	LO over Rated Band	
IQM-20A-***B	5 - 1000	10% of f_0	12	10	$\pm 2^\circ$	$\pm 1^\circ$	$\pm 5^\circ$	$\pm 3^\circ$	0.2	0.1	0.5
IQM-4A-***B	5 - 300	67% of f_0	12	10	$\pm 5^\circ$	$\pm 3^\circ$	$\pm 5^\circ$	$\pm 3^\circ$	0.5	0.3	0.5

For complete Model Number replace *** with desired LO Center Frequency, f_0 in MHz

Package Outline

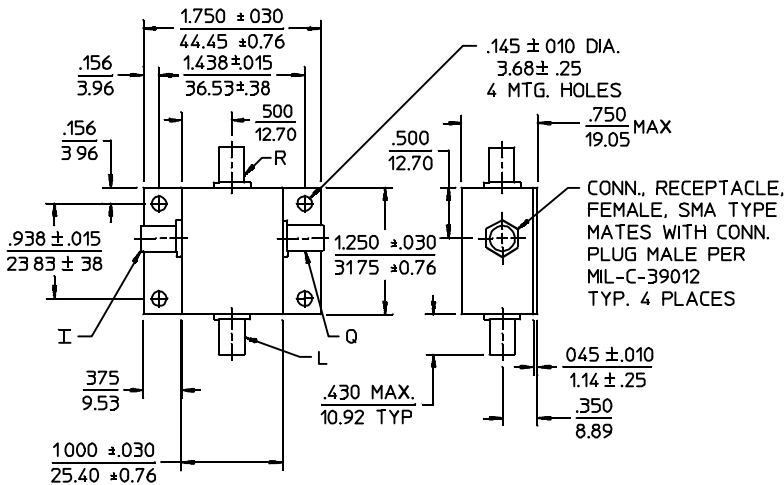

NOTES: 1. Tolerance on 3 place decimals $\pm .020(.51)$ except as noted.
2. Dimensions in inches over mm.

GENERAL SPECIFICATIONS

RF and LO Input Characteristics

Impedance: 50 Ω nom.

VSWR: 1.5:1 max.

RF Power Level: 0 dBm nom.

LO Power Level: +10 dBm nom.

Video Bandwidth, nom: DC to \dagger 50 MHz

Output Impedance: 50 Ω nom.

Weight, nominal: 2 oz (57 g)

Operating Temperature: -55° to $+85^\circ$ C

\dagger RF and Video Bandwidths are dependent on the center frequency, and are typically much greater than specified.

AVAILABLE OPTIONS

Higher Frequencies, alternate bandwidths and different packages also available.

General Notes:

1. I & Q networks are integrated networks that produce two quadrature phased, equal amplitude signals when fed RF and LO signals.
2. The IQM-A series uses lumped element circuits for small size and high performance.
3. Merrimac I & Q networks comply with the relevant sections of MIL-M-28837 and may be supplied screened for compliance with additional specifications for military and space applications requiring the highest reliability.

23Feb96