

# COMPLEX MODULATORS and DEMODULATORS (I & Q NETWORKS) 10 to 8,000 MHz GENERAL INFORMATION

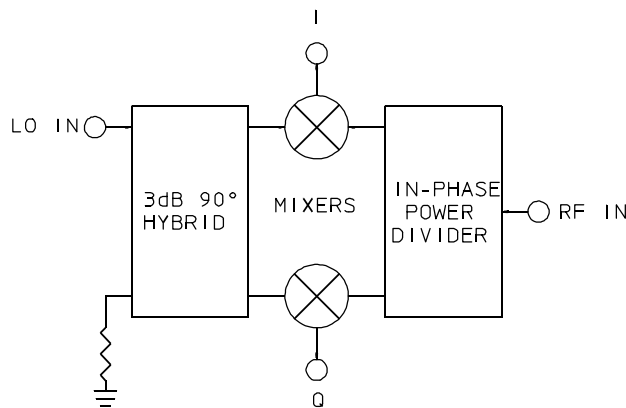

## The I & Q Network: Background

The I & Q network is a widely used functional building block found in communications, control and signal processing systems. When fed RF and LO inputs, it produces two equal amplitude, quadrature phased output signals. The typical I & Q network is illustrated in Figure 1.



**Figure 1. The Basic I & Q Network**

Depending on its specific application, the I & Q network may be known by a variety of other names such as:

- I & Q Phase Detector
- I & Q Modulator
- Phase Comparator
- QPSK Modulator/Demodulator
- Quadrature Generator/Phase Detector
- Quadrature Modulator/Demodulator
- Quadrature IF Mixer
- Vector Modulator

When additional passive components are combined with the basic I & Q network, the result can be various related functional building blocks such as Single Sideband Modulators, Image Reject Mixers, Phase Correlators and Phase Locked Loop systems.

## The I & Q Network as a Detector

One of the disadvantages of a simple phase detector is that its output is dependent on *both* the phase and amplitude of the inputs. This limits the ultimate accuracy attainable.

This difficulty is averted when an I & Q network is used. Taking the ratio of the I and Q outputs yields the inverse tangent ( $\tan^{-1}$ ) of the subject phase angle. The inverse tangent depends only on the phase component of the I and Q outputs and is thus independent of the amplitude components of I and Q. This increases potential I & Q device accuracy compared to a simple phase detector.

In phase modulated digital signaling, the number of states is usually a power of two such as 2, 4, 8 or higher. Increasing the number of states requires proportionately better phase accuracy performance by all components in the signaling chain. Merrimac offers a variety of I & Q networks with various degrees of phase accuracy suited to a broad range of price/performance points.

The principal bandwidth limiting element in an I & Q network is the 90° Quadrature Hybrid. To insure maximum network bandwidth, therefore, the LO signal (which is normally held constant) is fed to the 90° Quadrature Hybrid which is optimized for the specific LO frequency used. The RF signal is normally fed to the 0° Power Divider which has essentially unlimited bandwidth.

The video bandwidth of an I & Q network is also unlimited unless duplexers are included to attenuate harmonics and other spurious in-band signals. In practice, the video bandwidth covers at least DC to 500 MHz facilitating wideband data signal processing.

Phase accuracy and isolation of the 90° Quadrature Hybrid at the LO frequency is also important for insuring overall performance. In addition, to avert internal reflections leading to diminished mixer performance, the mixer inputs should be well matched to the impedance of the I and Q signal sources.

Obviously, the well designed I & Q network should exhibit stability under the variables of temperature and frequency. Merrimac offers a line of I & Q networks that include in-circuit trimming adjustments. These serve to assure the best possible interface between the I & Q network and the system in which it is embedded. The adjustable I & Q network models afford "trim" for either (or both) phase and amplitude balance.

Merrimac also offers many of its standard I & Q networks with SMA connector equipped packages that are especially

Special Feature	Example Model	Package Type	Approx. Size	Range of RF/LO, MHz	Bandwidth of LO, MHz	Phase Balance		Amplitude Balance	
						typ.	max.	typ.	max.
<b>Narrowband</b>	IQG-20E	Surface Mt.	0.8" sq.	20 - 1000	fixed LO	$\pm 1^\circ$	$\pm 2^\circ$	0.1 dB	0.2 dB
	IQP-20R	Meri-Pac™	0.8" sq.	20 - 1000	fixed LO	$\pm 1^\circ$	$\pm 2^\circ$	0.1 dB	0.2 dB
	IQF-20E	Flatpack	0.8" sq.	20 - 1000	fixed LO	$\pm 1^\circ$	$\pm 2^\circ$	0.1 dB	0.2 dB
<b>Octave BW</b>	IQP-4S	Meri-Pac™	1" sq.	1000 - 2000	Octave	$\pm 3^\circ$	$\pm 5^\circ$	0.2 dB	0.5 dB
<b>Multi-Octave</b>	IQM-9B	SMA	2"x 3"	30 - 1000	30 - 1000	$\pm 3^\circ$	$\pm 5^\circ$	0.2 dB	0.5 dB
<b>Cellular/PCN</b>	IQT-20A	TO-8	0.6" dia.	800 - 1800	Fixed/10%	$\pm 1^\circ$	$\pm 2^\circ$	0.2 dB	0.5 dB
<b>Ultra Wideband</b>	IQM-7C	SMA	2"x 3"	1 - 100	100:1	$\pm 3^\circ$	$\pm 5^\circ$	0.3 dB	0.5 dB
<b>Integral Video Amps</b>	IVM-20B	SMA	2"x 3"	70 - 500	100	$\pm 2^\circ$	$\pm 4^\circ$	0.1 dB	0.2 dB
<b>Phase Adjustable</b>	IQF-25F	Flatpack	1" sq.	20 - 1000	10% of $f_0$	Tunable $\pm 5^\circ$		0.1 dB	0.2 dB
<b>Phase &amp; Amp Adjustable</b>	IQP-27U	Meri-Pac™	1"x1.5"	20 - 200	10% of $f_0$	Tunable $\pm 5^\circ$		Tunable $\pm 1^\circ$	
<b>Image Reject Mixers</b>	IMF-2F/L	Flatpack	1" sq. 1"x1.5"	10 - 4000	10% of $f_0$	NA		NA	
<b>Dual I &amp; Q</b>	IDP-2S	Meri-Pac™	1" sq.	20 - 500	10% of $f_0$	$\pm 3^\circ$	$\pm 5^\circ$	0.5 dB	1.0 dB

**Table 1. Selection of Catalog I & Q Phase Detectors/Demodulators**

useful in prototyping situations. (Refer to units in the IQM series in this section )

### The I & Q Network as a Modulator

When used as a modulator, the I & Q network can control either (or both) the phase or amplitude of the RF carrier. The phase may be controlled either incrementally or continuously as in digital and analog modulation schemes, respectively. If the carrier phase is digitally modulated, the I & Q network often assumes a name that denotes the number of phase states allowed. For example, a Quadrature Modulator clearly provides *four* distinct output carrier phase states in response to the modulation input. In contrast, a "Vector Modulator" provides an output carrier whose phase is continuously variable over a finite range in response to the analog phase modulation input.

The I & Q network used as a Quadrature Modulator is optimized for greatest accuracy at 90° increments corresponding to the digital "words" 00, 01, 10, and 11. The unit illustrated in Figure 2 consists of two Bi-Phase Modulators combined with a 90° power divider and a 0° combiner.

By switching the Bi-Phase Modulators between 0° and 180° and combining the resultant vectors, four discrete equal amplitude phase states are generated. The modulators use fast switching Schottky-barrier diodes that reach the desired saturation level at 15 mA. However, this current level constrains the RF drive to no higher than +4 dBm if compression and resultant phase errors are to be avoided.

The Vector Modulator, as illustrated in Figure 3, has the same basic block diagram as a quadrature modulator and is

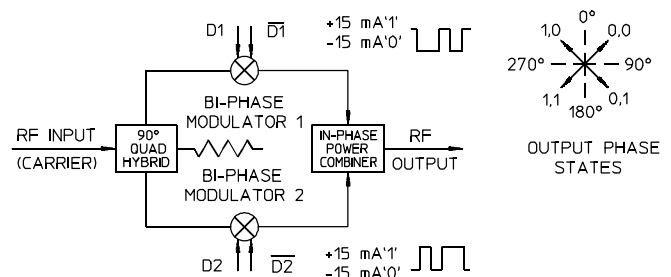

**Figure 2. The Quadrature Modulator and Resultant Vector Diagram**

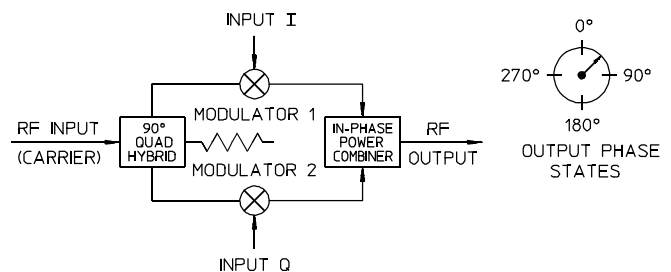

**Figure 3. The Vector Modulator and Resultant Vector Diagram**

In addition, the RF drive must be maintained within the +10 to +13 dBm range. Maintaining RF power at this level provides sufficient diode bias and assures acceptable VSWR regardless of input modulation levels.

To achieve phase modulation independent of amplitude variations, the I & Q network inputs must closely follow sine and cosine functions, respectively and have the same peak amplitude. Values for sine or cosine functions typically are derived from a “lookup table” in a PROM (programmable read-only memory). A digital word representing the desired phase angle is fed to the PROM which returns a digital word equal to the sine or cosine of the input angle. This value is then fed to a digital-to-analog converter which in turn precisely controls the mixer modulation. The result is a precisely controlled phase shift.

Transitioning from the analog to digital domains and back might seem error-prone. However, the A/D, PROM and D/A devices can be made arbitrarily precise by increasing the digital word width, i.e., increase the number of significant digits. This assures the overall result can be superior both in theory and in practice to purely analog methods in terms of monotonicity, for example.

To achieve amplitude control of the vector in addition to the phase angle, the scale factor (K) of the sine and cosine functions can also be modulated. An integrated component of this type can achieve 30 to 40 dB of output attenuation if K is equal to 0. This is equal to the residual L-R isolation minus the conversion loss.

However, at full attenuation the residual error vector of the L-R signal will cause significant phase error. So vector modulators typically limit the output dynamic range to less than 20 dB.

### More Complex I & Q Networks

A special feature of the I & Q network is its ability to discriminate between the upper and lower sidebands in either modulators or demodulators. When used as a modulator, the I & Q network is known as a “Single Sideband Modulator”. When used in a demodulator, the I & Q network is called an “Image Reject Mixer.” Each is composed of the conventional I & Q network with the I and Q inputs fed signals with a relative phase difference of 90°. This can be accomplished externally or with the internal addition of a 90° quadrature hybrid as shown in Figure 4.

Creating the required quadrature phase relationship externally is advantageous since the modulation bandwidth is not limited by the bandwidth of the quadrature hybrid. Thus, the

operating range can extend down to DC; an important consideration in digital transmission.

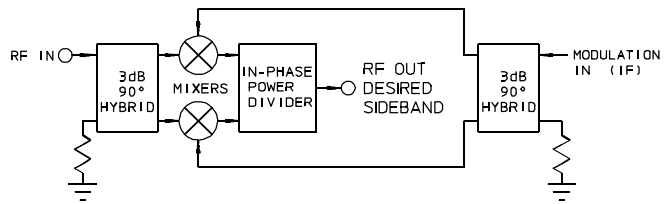

**Figure 4. The Single Sideband Modulator**

### The Single Sideband Modulator

The Single Sideband Modulator is especially useful in modulator applications where the desired and undesired RF sidebands are so close in frequency that it is impractical to separate them using a simple bandpass filter or where minimum group delay is required.

The undesired sideband is canceled within the unit (internally terminated) using vector subtraction while the desired sideband is reinforced at the output. The level of cancellation is usually given as the sideband rejection ratio expressed in dB.

Figure 4 shows a configuration of circuit elements that allows desired sideband signals from the two mixers to be combined in-phase at the RF output port, while the undesired sideband signals self-cancel. At the image port, the reverse occurs and the unwanted sideband signal is absorbed by the load resistor (internal in Merrimac’s design.)

There are several other considerations affecting image rejection. Some of them are the phase and amplitude balances of each component chosen, mixer sensitivity, VSWR interaction, bandwidth, etc.

Figure 5 is a useful guide to the signal rejection that may be obtained with a given phase error and amplitude balance. These curves provide valuable insight to the inherent tradeoffs between the allowable phase and amplitude errors to attain the desired sideband rejection ratio.

### The Image Reject Mixer

The foregoing description of the I & Q network as a Single Sideband Modulator also applies to the I & Q network when used as an Image Reject Mixer such as would be found in a receiver or down-converter. Whether a unit is optimized during production for use as a sideband modulator or as an image reject mixer depends on what application the customer specifies for the unit.

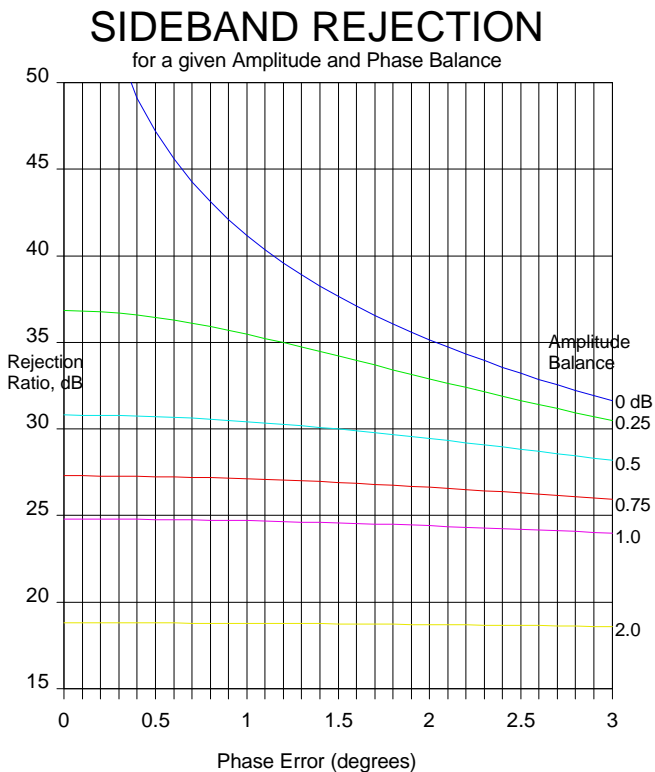

Figure 5. Theoretical Sideband Rejection for a

### The Phase Comparator

The Phase Comparator provides two output voltages which, taken together, permit unambiguous phase comparisons to be made across the entire  $0^\circ$  to  $360^\circ$  range. One output is proportional to the *sine* of the phase difference between the reference (LO) and the unknown (RF) input signals, while the other output is proportional to the *cosine*.

The integrated component, shown in Figure 6, is essentially an I & Q network with a phase shifter in the LO path to set a reference phase. This forces output signal zero-crossings to occur at an RF-LO phase difference of  $0^\circ$  or  $90^\circ$  respectively. Two diplexers are added in the I & Q output paths to band limit the video bandwidth and especially to attenuate the second harmonic ( $2 f_0$ ).

A Phase Comparator is most suited to *Test and Measurement* applications rather than dynamic information detection where the basic I & Q demodulator circuit excels.

### Why Use an Integrated Component?

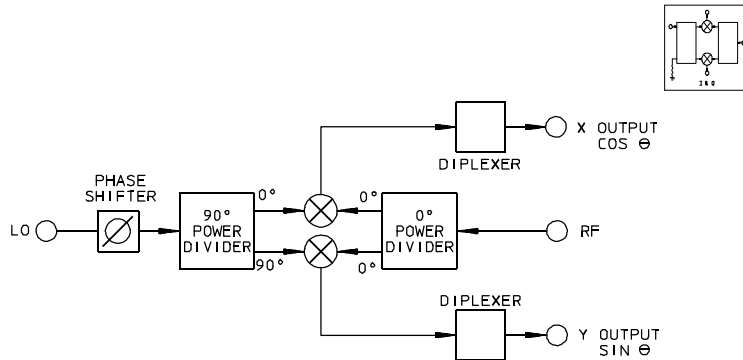

Figure 6. The Phase Comparator

In traditional circuit design, I & Q networks are comprised of discrete components. Historically, this was the only practical approach to achieving the desired amplitude and phase balance and involved closely matching each component. The process was both costly and lacking in consistently reliable results.

Designers have therefore often taken the logical step of adding in-circuit phase and amplitude tuning elements to facilitate trimming during the manufacturing process. Unfortunately, this increases unit complexity and is a major factor in determining overall unit cost.

With long experience in I & Q networks, Merrimac has successfully automated trimming of mixer characteristics using very short, precisely controlled line lengths between components that are independent VSWR. This results in a compact, stable product with accuracies superior to those composed of discrete components.

The advantages of using a Merrimac I & Q networks include:

1. Reducing unit complexity is a “high leverage” cost reduction factor .
2. Reduced installation time because of integrated unit
3. Integration assures minimum “real-estate” used
4. Consistent installation procedures and durations
5. Specifications are more easily and consistently met
6. Enhanced reliability through lower parts count

The net effect is **improved system performance**. Merrimac I & Q networks are suitable for a wide assortment of applications varying in frequency, bandwidth and accuracy. Moreover, if we don't currently have a model that meets your requirements, we'll be pleased to carefully analyze your needs and respond with a proposal to fill them.