

Application Note for IQ Network, IQ-MCM-1.9G

Introduction:

IQ networks provide two equal amplitude and quadrature phase IF outputs, at the difference frequency of the RF and LO inputs. The network is composed of one quadrature hybrid (QHD-2Z-1.9G), one 2-way power divider (PDD-2Z-2.0G) and two surface mount mixers, as shown in the block diagram of Figure 1.

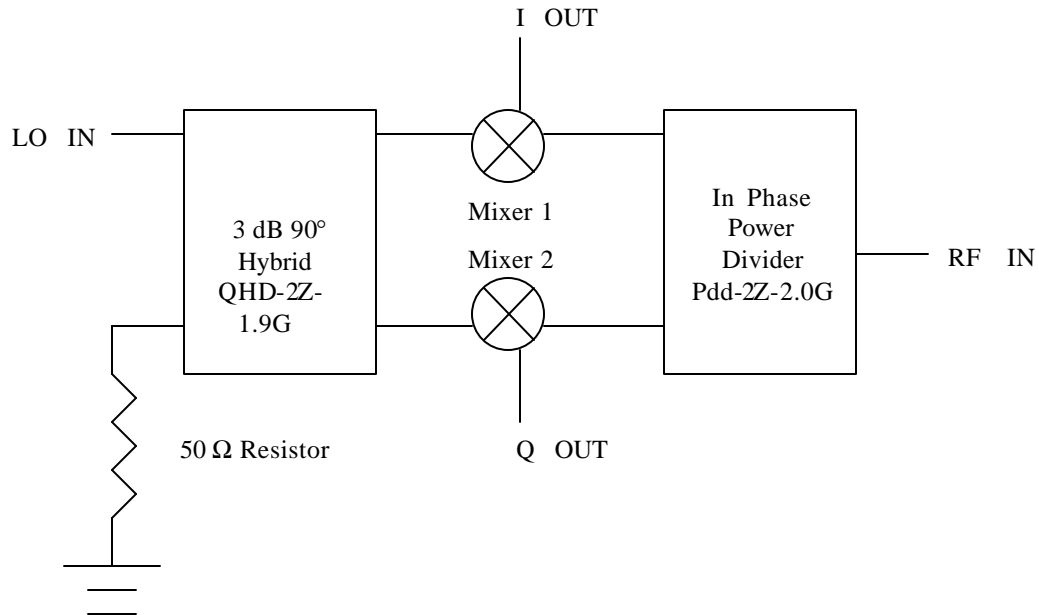

Figure 1: Block Diagram of IQ Demodulator

Theory of Operation:

The input RF signal is fed to the in phase divider and split before feeding the RF ports of the two double balanced mixers. The LO signal is fed to the hybrid and split with a 90° phase shift between the two outputs before feeding the LO ports of the two double balanced mixers. The two double balanced mixers provide the IF outputs (I and Q) that are equal in amplitude, but in phase quadrature.

The mixers effectively multiply the RF and LO signals, and since the quadrature hybrid introduces a 90 degree phase difference, mixer1 multiplies $(\cos \omega_{LO}t)(\cos \omega_{RF}t)$, while mixer2 multiplies $(\sin \omega_{LO}t)(\cos \omega_{RF}t)$. The trigonometry results in sum and difference frequencies, of which the difference frequency is chosen. When the LO frequency is greater than the RF frequency, Q leads I by 90 degrees. When the RF frequency is greater than the LO frequency, Q lags I by 90 degrees.

Implementation:

Mixers, quadrature hybrid and power divider are surface mounted on 0.8 x 0.8 circuit board, and interconnected using coplanar transmission line, as seen in figure 2. The outline drawing of the assembly shows a surface mount footprint, which also accepts edge launch SMA connectors. Two inductors and two capacitors are used in this application to match the RF port, due to the inherent mismatch in of the mixers. See Figure3 for detailed layout.

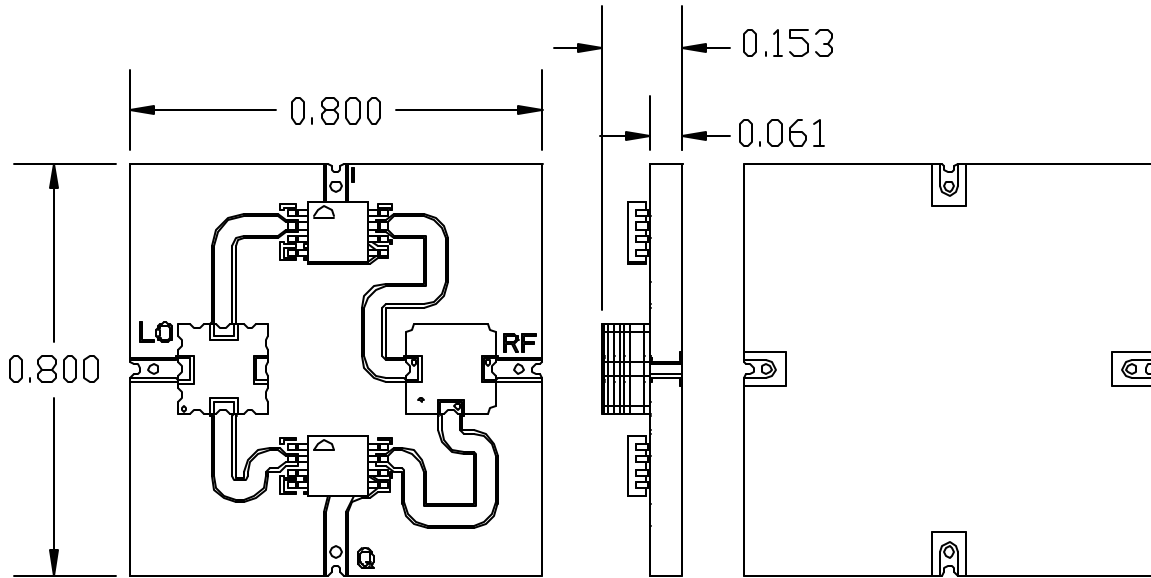

Figure2: Outline drawing

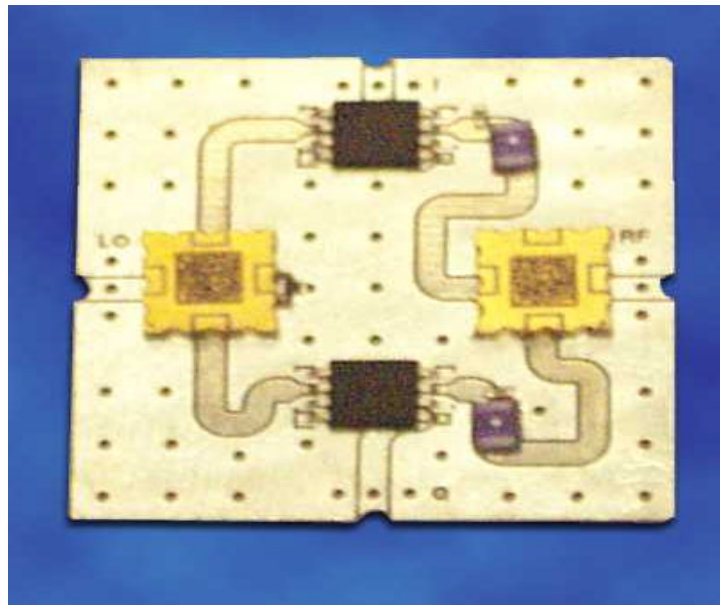

Figure3: Implementation including matching inductors and capacitors

Applications:

The IQ network can be used as a phase detector, phase comparator, quadrature IF mixer, M-ary PSK demodulator, or QAM demodulator. It can also be used as the basic building block in single sideband modulators, image reject mixers, and phase correlators.

Results:

LO input power : 16 dBm

Parameters	Specification
Frequency Range, RF & LO	1.7 – 2.0 GHz
I, Q Bandwidth	DC – 300 MHz
LO, RF, I, Q Impedance	50 ohms
Conversion Loss	-14.5 dB
Input 1dB Compress Point	+13 dBm
Input IP3 point	+21dBm
LO, RF, LO VSWR	2.0 : 1
Isolation RF to I, Q	14 dB
Isolation LO to I, Q	30 dB
Isolation LO to RF	40 dB
Amplitude Balance	+/- 0.65 dB
Phase Balance	+/- 3.5
Size / Outline	0.80 x 0.80 inches
RF Interface	Surface Mount / removable SMA
Operating Temperature Range	-55 to 85, C

